

INTERNATIONAL
STANDARD

BS ISO 29942:2011
ISO
29942

First edition
2011-07-01

**Prophylactic dams — Requirements and
test methods**

Membranes prophylactiques — Exigences et méthodes d'essai

DATE OF ISSUED: 06 OCT 2021.

UNCONTROLLED COPY



Reference number
ISO 29942:2011(E)

© ISO 2011



COPYRIGHT PROTECTED DOCUMENT

© ISO 2011

All rights reserved. Unless otherwise specified, no part of this publication may be reproduced or utilized in any form or by any means, electronic or mechanical, including photocopying and microfilm, without permission in writing from either ISO at the address below or ISO's member body in the country of the requester.

ISO copyright office
Case postale 56 • CH-1211 Geneva 20
Tel. + 41 22 749 01 11
Fax + 41 22 749 09 47
E-mail copyright@iso.org
Web www.iso.org

Published in Switzerland

Contents

Page

Foreword	iv
Introduction.....	v
1 Scope	1
2 Normative references	1
3 Terms and definitions	2
4 Quality verification	3
5 Design.....	4
6 Barrier properties	5
7 Biocompatibility.....	5
8 Surface finish.....	5
9 Tensile properties.....	5
10 Tests for stability and shelf-life	6
11 Freedom from holes	7
12 Visible defects	7
13 Packaging and labelling.....	7
14 Data sheets	10
Annex A (normative) Sampling plans intended for assessing compliance of a continuing series of lots of sufficient number to allow the switching rules to be applied.....	11
Annex B (normative) Sampling plans intended for assessing compliance of isolated lots	12
Annex C (normative) Determination of length and width	13
Annex D (normative) Determination of dam thickness.....	14
Annex E (informative) Guidance for risk assessment.....	15
Annex F (normative) Determination of barrier properties using the bacteriophage method	17
Annex G (normative) Determination of tensile properties.....	21
Annex H (normative) Oven conditioning	22
Annex I (normative) Determination of shelf-life by real-time stability studies	23
Annex J (informative) Guidance on conducting and analysing accelerated ageing studies.....	25
Annex K (normative) Testing for holes.....	27
Bibliography.....	29

Foreword

ISO (the International Organization for Standardization) is a worldwide federation of national standards bodies (ISO member bodies). The work of preparing International Standards is normally carried out through ISO technical committees. Each member body interested in a subject for which a technical committee has been established has the right to be represented on that committee. International organizations, governmental and non-governmental, in liaison with ISO, also take part in the work. ISO collaborates closely with the International Electrotechnical Commission (IEC) on all matters of electrotechnical standardization.

International Standards are drafted in accordance with the rules given in the ISO/IEC Directives, Part 2.

The main task of technical committees is to prepare International Standards. Draft International Standards adopted by the technical committees are circulated to the member bodies for voting. Publication as an International Standard requires approval by at least 75 % of the member bodies casting a vote.

Attention is drawn to the possibility that some of the elements of this document may be the subject of patent rights. ISO shall not be held responsible for identifying any or all such patent rights.

ISO 29942 was prepared by Technical Committee ISO/TC 157, *Non-systemic contraceptives and STI barrier prophylactics*.

Introduction

A prophylactic dam is used to cover parts of the human body during sexual contact. The prophylactic dam (hereinafter also referred to as “dam”) provides coverage to the external female genitalia or the anal area. Non-porous, intact, polymer films have been demonstrated as barriers to the human immunodeficiency virus (HIV) and other infectious agents responsible for the transmission of sexually transmitted infections (STIs). To be effective, it is essential that dams be free from holes and defects, have adequate physical properties so as not to break during use, be correctly packaged to protect them during storage and be correctly labelled to facilitate their use.

To be safe, it is essential that the dam and additive, dressing, individual packaging material or powder applied to it neither contain nor liberate substances in amounts that are toxic, sensitizing, locally irritating or otherwise harmful under normal conditions of storage or use.

Prophylactic dams are non-sterile medical devices; however, a clean environment is essential to minimize microbiological and particulate contamination of the product during manufacturing and packaging. To ensure a high-quality product, it is essential that it be designed and produced under a good quality management system. See ISO 13485 and ISO 14971 for more details on risk management and quality management.

It is intended that manufacturers conduct stability tests to estimate the shelf-life of any new or modified design before the product is placed on the market. These tests are intended to ensure that manufacturers have adequate data to support shelf-life claims before products are placed on the market and that these data are available for review by regulatory authorities, test laboratories and purchasers. They are also intended to limit the need for third parties to conduct long-term stability studies. Real-time shelf-life studies are also initiated, but not necessarily completed, prior to placing the product on the market.

Prophylactic dams — Requirements and test methods

1 Scope

This International Standard specifies the minimum requirements and test methods for prophylactic dams used to assist in the prevention of sexually transmitted infections.

2 Normative references

The following referenced documents are indispensable for the application of this document. For dated references, only the edition cited applies. For undated references, the latest edition of the referenced document (including any amendments) applies.

ISO 34-1, *Rubber, vulcanized or thermoplastic — Determination of tear strength — Part 1: Trouser, angle and crescent test pieces*

ISO 37, *Rubber, vulcanized or thermoplastic — Determination of tensile stress-strain properties*

ISO 188, *Rubber, vulcanized or thermoplastic — Accelerated ageing and heat resistance tests*

ISO 2859-1:1999, *Sampling procedures for inspection by attributes — Part 1: Sampling schemes indexed by acceptance quality limit (AQL) for lot-by-lot inspection*

ISO 4074, *Natural latex rubber condoms — Requirements and test methods*

ISO/TR 8550-1, *Guidance on the selection and usage of acceptance sampling systems for inspection of discrete items in lots — Part 1: Acceptance sampling*

ISO/TR 8550-2, *Guidance on the selection and usage of acceptance sampling systems for inspection of discrete items in lots — Part 2: Sampling by attributes*

ISO 10993-1, *Biological evaluation of medical devices — Part 1: Evaluation and testing within a risk management process*

ISO 10993-5, *Biological evaluation of medical devices — Part 5: Tests for in vitro cytotoxicity*

ISO 10993-10, *Biological evaluation of medical devices — Part 10: Tests for irritation and skin sensitization*

ISO 10993-11, *Biological evaluation of medical devices — Part 11: Tests for systemic toxicity*

ISO 13485, *Medical devices — Quality management systems — Requirements for regulatory purposes*

ISO 14971, *Medical devices — Application of risk management to medical devices*

ISO 15223 (all parts), *Medical devices — Symbols to be used with medical device labels, labelling and information to be supplied*

3 Terms and definitions

For the purposes of this document, the terms and definitions given in ISO 2859-1 and the following apply.

3.1

acceptance quality limit

AQL

quality level that is the worst tolerable process average when a continuing series of lots is submitted for acceptance sampling

[ISO 2859-1:1999, definition 3.1.26]

3.2

consumer package

package intended for distribution to a consumer, containing one or more individual containers of prophylactic dams

3.3

date of manufacture

date of formation of the prophylactic dam

3.4

expiry date

date after which the prophylactic dam cannot be used

3.5

prophylactic dam

piece of polymer film that prevents the transmission of micro-organisms, which can cause sexually transmitted infections, and is designed to cover the anal area and/or the external female genitalia

3.6

identification number

number, or combination of numerals, symbols or letters used by a manufacturer on consumer packages to uniquely identify the lot numbers of individual prophylactic dams contained in that package, and from which it is possible to trace those lots through all stages of manufacturing, packaging and distribution

NOTE Whenever the consumer package contains only one kind of prophylactic dam, the identification number can be the same as the lot number. However, if the consumer package contains several different types of prophylactic dam, for instance prophylactic dams of different shapes or colours, the identification number is different from the lot numbers.

3.7

individual container

primary package containing a prophylactic dam

3.8

inspection level

relationship between lot size and sample size

NOTE For a description, see ISO 2859-1:1999, 10.1.

3.9

lot

collection of dams of the same design, colour, shape, size and formulation, manufactured at essentially the same time, using the same process, raw materials of the same specifications, common equipment and packed with the same lubricant and any other additive or dressing in the same type of individual container

NOTE This International Standard does not specify the size of a lot, but it is possible for a purchaser to do so as part of the purchasing contract. Attention is drawn to the difficulties that can be associated with the distribution and control of very large lots. The recommended maximum individual lot size for production is 500 000.

3.10

lot number

number or combination of numerals, symbols or letters used by the manufacturer to identify a lot of individually packaged dams, and from which it is possible to trace that lot through all stages of manufacture up to packaging

3.11

lot test

test to assess the conformity of a lot

NOTE A lot test can be limited to include only those parameters that can change from lot to lot.

3.12

non-visible hole

hole in a dam that is not visible under normal or corrected vision, but is detected by a suitable water leak test

3.13

sampling plan

specific plan that indicates the number of units of product from each lot which are to be inspected (sample size or series of sample sizes) and the associated criteria for determining the acceptability of the lot (acceptance and rejection numbers)

3.14

shelf-life

period of time from the date of manufacture over which the product is claimed to conform to the specified requirements

3.15

visible hole

hole in the dam that is visible under normal or corrected vision before the dam is exposed to water during testing for holes

3.16

visible defect

(other than hole) permanent crease with adhesion of the film, or other materials embedded in the film

4 Quality verification

Dams are produced in large quantities. Inevitably there is some variation between individual prophylactic dams. A small proportion of dams in each production run might not meet the requirements of this International Standard. Furthermore, the majority of the test methods described in this International Standard are destructive. For these reasons, the only practicable method of assessing conformity with this International Standard is by testing a representative sample from a lot or series of lots. Sampling plans referred to in this International Standard are identified in ISO 2859-1. Refer to ISO/TR 8550-1 for guidance on acceptance sampling in general, and to ISO/TR 8550-2 for the selection of alternative acceptance sampling systems, for the inspection of discrete items in a lot. For testing purposes, sampling shall be conducted by lot number, not by identification number. Handling and storage conditions shall be documented before drawing the samples.

Sampling plans shall be selected to provide an acceptable level of consumer protection. Suitable sampling plans are given in Annexes A and B.

Annex A describes sampling plans based on ISO 2859-1 and is most applicable to manufacturers or purchasers assessing the conformity of a continuing series of lots. The full level of consumer protection available depends upon the switch to tightened inspection if deterioration in quality is detected. The switching rules cannot offer full protection for the first two lots tested, but become progressively more effective as the number of lots in a series increases. The sampling plans in Annex A are applicable whenever five or more lots are being tested.

Annex B describes sampling plans, based on ISO 2859-1, which are recommended for the assessment of isolated lots. It is recommended that these sampling plans be used for the assessment of fewer than five lots, for example in cases of dispute, for referee purposes, for type testing, for qualification purposes or for short runs of continuing lots.

It is necessary to know the lot size in order to derive from ISO 2859-1 the number of dams to be tested. The lot size varies between manufacturers and is regarded as part of the process and quality controls used by the manufacturer.

Where initial or ongoing quality verification for dams is required, it is suggested that, instead of concentrating solely on evaluation of the final product, the party concerned also assess the manufacturer's quality system. ISO 13485 specifies the provision of an integrated quality system.

5 Design

5.1 General

A prophylactic dam is a piece of polymer film that is used to prevent transmission of micro-organisms, which can cause STIs. It is intended to cover the anal area or the external female genitalia. Dams shall be designed to prevent STIs during sexual activity.

5.2 Dressing materials

The dam may be coated with dressing materials intended to protect it in storage, or with flavours or perfumes. Any dressing material used shall be non-cytotoxic, non-sensitizing and non-irritating, respectively, and suitable for human consumption. The dressing material shall not have any deleterious effects on the barrier membrane.

5.3 Dimensions

5.3.1 Length

The length of a dam shall be between 200 mm and 350 mm. When tested in accordance with the method given in Annex C, taking 13 dams from each lot, no measurement shall be outside the specified range.

5.3.2 Width

The width of a dam shall be between 150 mm and 250 mm. When tested in accordance with the method given in Annex C, taking 13 dams from each lot, no measurement shall be outside the specified range.

5.3.3 Thickness

Whenever measured in accordance with Annex D, the mean thickness of the dam shall be not more than 0,15 mm. No single reading shall be below 75 % of the mean and no single reading shall be above 125 % of the mean.

For dams made from natural rubber latex, no single thickness measurement shall be less than 0,04 mm.

5.4 Risk assessment

5.4.1 A risk assessment for the product shall be conducted in accordance with ISO 14971. The assessment shall identify potential failure modes for the device as well as any other safety and efficacy concerns. Manufacturers shall make the results of the risk assessment for the design, as described in Annex E, available to regulatory authorities on request.

5.4.2 The manufacturer shall identify and define all reasonably predictable failure modes during the analysis, and these failure modes shall be considered part of the design of the device.

6 Barrier properties

This clause applies only to products made from materials other than natural rubber latex.

The barrier properties of the dam shall be established by viral penetration studies using a suitable surrogate virus, for example bacteriophage phi-X 174. Where tested in accordance with the method given in Annex F, viral penetration properties shall be compared with those of a hole-free male latex condom that meets the requirements of ISO 4074.

The viral penetration per unit area shall be no more than 150 % of the penetration found for the control dam.

7 Biocompatibility

Biocompatibility for the finished product and its components shall be established in accordance with ISO 10993-1. Since the dam is in repeated contact with surface mucosa and possibly compromised tissue surfaces, the testing shall be conducted to demonstrate that the materials are not cytotoxic and do not cause sensitization, mucosal irritation or acute systemic toxicity, in accordance with the relevant clauses of ISO 10993-1, ISO 10993-5, ISO 10993-10 and ISO 10993-11, respectively. If there is a likelihood of systemic absorption of any components or residuals, mutagenicity testing shall be performed. All data generated in these evaluations shall be made available to regulatory authorities on request.

The manufacturer shall also obtain, and make available to regulatory authorities on request, toxicity data on all the additives and residual monomers, solvents and known impurities used in the manufacture of the dam subject to this International Standard. Suitable material safety data sheets shall be supplied on request for materials used in the manufacture of products conforming to this International Standard.

NOTE Attention is drawn to provisions in ISO 10993-1 that do not require specific tests on the product, provided it is made from materials whose biocompatibility is already established.

8 Surface finish

Place the barrier membrane (dam) on a light box and examine under normal or corrected vision. The latex barrier membrane should have a smooth surface finish on both sides. It shall be free from ingrained particles, blisters, air bubbles and other imperfections, which would detract from its serviceability.

9 Tensile properties

9.1 Natural rubber latex dams

9.1.1 Tensile strength and elongation

Where tested in accordance with the method specified in Annex G using type 1, type 1A or type 2 dumb-bell test pieces, the minimum tensile strength and elongation at break shall comply with the requirements given in Table 1.

NOTE type 1A dumb-bells are preferable, if available.

9.1.2 Tear resistance

Where tested both longitudinally and transversely in accordance with ISO 34-1, method A (trouser tear test), the minimum value of the tearing force (the force at the onset of tearing) and tear resistance shall comply with the requirements of Table 1.

Table 1 — Minimum tensile properties and tear resistance

Tensile property	Minimum requirements
Tensile strength, MPa	21
Elongation at break, %	650
Tear resistance, N/mm	5
Tearing force, N	0,5

An AQL of 2,5 shall apply.

9.2 Dams made from other materials

9.2.1 General

As part of the risk assessment in 5.4, the manufacturer shall determine suitable minimum values for the tensile strength, elongation at break, tear resistance and tearing force, and make these values publicly available as part of the device specification. Where the material used is already commonly used for other products and its physical properties are published, the minimum values shall be at least similar to the published properties of the material.

9.2.2 Tensile properties

Where tested in accordance with the method specified in Annex G using type 1, type 1A or type 2 dumb-bell test pieces, the minimum tensile strength and elongation at break shall comply with the minimum values developed by the manufacturer. An AQL of 2,5 shall apply to these values.

9.2.3 Tear resistance

Where tested both longitudinally and transversely in accordance with ISO 34-1, method A (trouser tear test), the minimum value of the tearing force (the force at the onset of tearing) and tear resistance shall comply with the requirements developed by the manufacturer. An AQL of 2,5 shall apply to these values.

10 Tests for stability and shelf-life

10.1 General

Manufacturers shall verify that the dams satisfy the requirements for freedom from holes, visible defects, tensile strength and tear resistance given in Clauses 9 and 11 until the end of the labelled shelf-life. Shelf-life claims shall not exceed five years.

Data supporting the shelf-life claims made by the manufacturer shall be made available to the appropriate regulatory authorities and direct purchasers upon request.

Before a new or modified prophylactic dam design is placed on the market, the following requirements shall be met:

- a) the dam shall be tested for the minimum stability requirements as described in 10.2;
- b) a real-time stability study, as described in 10.3, to determine shelf-life shall have commenced;
- c) pending completion of the real-time stability study, shelf-life shall be estimated as described in 10.4.

10.2 Minimum stability requirements

Three lots of dams shall be tested for conformity to Clauses 9 and 11 using the sampling plans given in Annex B. Only lots meeting all these requirements shall be used for the remainder of this test.

Condition samples in their individual containers in accordance with Annex H, one set for (168 ± 5) h (one week) at (70 ± 2) °C and the other set for (90 ± 1) days at (50 ± 2) °C. At the end of the oven conditioning, withdraw the prophylactic dams and test for tensile and tear properties in accordance with Annex G and the requirements of 9.1 and 9.2.

NOTE Data used to verify compliance with 10.2 can be extracted from studies for estimates of shelf-life (see 10.4).

10.3 Procedure for determining shelf-life by real-time stability studies

After testing in accordance with Annex I, the dams shall meet the requirements of Clauses 9 and 11.

If the real-time data indicate a shorter shelf-life than that claimed on the basis of accelerated ageing (see 10.4), the manufacturer shall notify the relevant regulatory authorities and direct purchasers. The manufacturer shall change the shelf-life claim for the product to one based on the real-time stability study. In no case shall shelf-life exceed five years. For prophylactic dams placed on the market, real-time stability studies shall be completed for the full period of the shelf-life claim.

If the dams, as supplied to the consumer, are packed in a transparent pack, exposing the dam to light, then the real-time stability study shall also expose the dams to light at a level and duration similar to what could be expected in storage.

10.4 Estimating shelf-life based on accelerated stability studies

Pending the completion of real-time stability studies, accelerated stability studies shall be used to estimate the provisional shelf-life. Shelf-life estimates shall be based on a mean kinetic temperature of (30_{-2}^{+5}) °C for all climatic conditions and may be carried out on prophylactic dams from the same production lots as used for real-time determination of shelf-life.

For dams made from natural rubber latex, conditioning at (50 ± 2) °C for 90 days may be taken as equivalent to two years at (30 ± 2) °C, conditioning at (50 ± 2) °C for 120 days may be taken as equivalent to three years at (30 ± 2) °C and conditioning (50 ± 2) °C for 180 days may be taken as equivalent to five years at (30 ± 2) °C, for the purpose of establishing provisional shelf-life.

11 Freedom from holes

Where dams are tested for freedom from holes in accordance with the method described in Annex K, the AQL and inspection level established in Annexes A and B shall apply. An AQL of 0,25 shall apply to this test.

12 Visible defects

Where dams are tested for visible defects as described in Annex K, the AQL and inspection level established in Annexes A and B shall apply. An AQL of 1,0 shall apply to this test.

13 Packaging and labelling

13.1 Packaging

Each dam shall be packed in a container. One or more individual containers may be packed in other packaging, such as a consumer package. Except as provided in this subclause, the individual container or

consumer package, or both, shall be opaque to light. Except as outlined in this subclause, the packaging shall protect the dam from light even if only the individual package is provided to the consumer. If dams are intended to be supplied only in individual containers, the individual containers shall be opaque.

Transparent packaging may be used if the manufacturer is able to supply data demonstrating that the product's appearance and tensile properties are not adversely affected by continuous exposure to white visible light at an incident intensity of 500 lx for one third of the shelf-life, or if exposure to daylight was simulated during the real-time shelf-life study.

While the devices are not intended to be sterile, packing shall be conducted under clean conditions, with suitable hygiene precautions enforced.

If a marking medium, such as ink, is used on a dam or on any part of a package directly in contact with a prophylactic dam, it shall not have any deleterious effect on the dam or be harmful to the user.

Individual containers and any other packaging shall protect the dam from damage during normal transportation and storage.

Individual containers and any other packaging shall be designed in such a way that the pack can be opened without damaging the prophylactic dam. The design of the individual container should facilitate easy opening.

13.2 Labelling

NOTE National regulations can apply in certain jurisdictions in relation to labelling for latex allergy, etc.

13.2.1 Symbols

If symbols are used on packaging, information and marketing materials, the symbols shall meet the requirements of ISO 15223 (all parts).

13.2.2 Individual containers

Each individual container shall be legibly and indelibly marked with at least the following information:

- a) the identity of the manufacturer and/or distributor;
- b) the manufacturer's identifying reference for traceability (e.g. the lot number);
- c) the expiry date (year and month). The format of the year shall be in four digits; the format of the month shall be in letters or two digits.

13.2.3 Consumer packages

13.2.3.1 General

The outside of the consumer package shall bear at least the following information in at least one of the official language(s) of the country of destination or as stipulated differently by that country:

- a) a description of the dam;
- b) the number of dams contained;
- c) the size designation, if that manufacturer makes more than one size, the name or trade name, country of manufacture and name and address of distributor, subject to national and regional requirements;
- d) the expiry date (year and month). The format of the year shall be in four digits and the format of the month shall be in letters or two digits. If a consumer package includes prophylactic dams from different lots, the earliest expiry date shall apply to all prophylactic dams;

- e) a statement of appropriate storage conditions for the dam materials;
- f) if appropriate, a statement that individual containers, if not opaque to light, shall not be stored outside the opaque consumer package;
- g) when a medicinal ingredient is added, it shall be identified and its purpose indicated (e.g. spermicidal). If the prophylactic dam is fragranced or flavoured, this shall be stated;
- h) the manufacturer's identifying reference for traceability (e.g. the identification number/lot number). If different types of dams, e.g. different colours, are packaged together in the same consumer package, the identification number on the consumer package shall allow the manufacturer to identify uniquely the lot numbers of the individual prophylactic dams contained in that package, so that it is possible to trace lots through all stages of manufacture up to packaging;
- i) a statement for dams made from natural rubber latex (NRL) that indicates that the dam contains natural rubber and draws attention to the risks of latex allergy.

13.2.3.2 Additional information for the consumer

The outside or the inside of the consumer package, or a leaflet contained within the consumer package, shall bear at least the following information expressed in simple terms, and in at least one of the official languages of the country of destination. If possible, this should also be supplemented by pictorial representations of the major steps involved or as stipulated differently by that country.

Instructions for use of the dam, including:

- a) the need to handle the dam carefully, including removal from the package so as to avoid damage to the dam by fingernails, jewellery, etc.;
- b) how and when to place and hold the dam;
- c) if an additional lubricant is desired, a statement instructing the user to use only the correct type of lubricant which is recommended. If the dam is made from natural rubber latex, also include a statement instructing the user to avoid the use of oil-based lubricants, such as petroleum jelly, baby oil, body lotions, massage oils, butter, margarine, as these are deleterious to the integrity of the material;
- d) a statement instructing the user to consult a doctor or pharmacist about the compatibility of topical medicines that might come in contact with the dam;
- e) a statement that the prophylactic dam is for single use;
- f) the reference number of this International Standard, i.e. ISO 29942:2011.

13.3 Inspection

When inspected, 13 consumer packages and 13 individual containers shall be selected from each lot and examined for conformity to 13.1, 13.2 and 13.3. All inspected containers shall conform to these requirements.

Under certain conditions, it may be permissible for the manufacturer/distributor to correct faults associated with packaging and labelling requirements and resubmit the lot for further conformity testing. Examples include the insertion of missing instruction leaflets or re-packaging of individual containers into new complete consumer packages before placing on the market.

If dams from the same lot are packed into different consumer packages, at least one consumer package of each variant should be inspected. The number of packages inspected should not exceed 13, unless the number of variants exceeds 13.

14 Data sheets

The manufacturer shall make available to all interested parties a data sheet that contains, for each product variant, at least the following information:

- a) specifications for length, width and thickness;
- b) specifications for amount and type of dressing materials (e.g. flavour, powder);
- c) list of materials used in the product;
- d) if the dam is made from materials other than natural latex rubber, the minimum tensile and tear properties.

Annex A (normative)

Sampling plans intended for assessing compliance of a continuing series of lots of sufficient number to allow the switching rules to be applied

If a party wishes to establish, by inspection and testing of samples of the final product, whether a continuing series of lots are in compliance with the requirements of this International Standard, the sampling plans and acceptance criteria given in Table A.1 shall be applied.

Manufacturers may use the schemes in Table A.1 or they may devise and implement validated alternative quality control methods that result in at least equivalent consumer protection.

When tests are being conducted on fewer than five lots of prophylactic dams, the additional protection of the switching rules in ISO 2859-1 is not available and it is recommended that the sampling plans given in Annex B be used to maintain the level of consumer protection.

Table A.1 — Sampling plans and acceptance criteria for a continuing series of lots

Attribute	Inspection level ^a	Acceptance criterion
Dimensions	13 dams	All samples shall fall within the specified limits
Tensile and tear properties	13 samples	AQL of 2,5
Package integrity	Special inspection level S-3	AQL of 2,5
Freedom from holes	General inspection level I	AQL of 0,25
Visible defects	General inspection level I	AQL of 1,0
Packaging and labelling	13 consumer packages and 13 individual containers	All shall comply
^a See ISO 2859-1 where relevant.		

Applications for these sampling plans include the following:

- a) ongoing production testing and quality control by a manufacturer;
- b) ongoing testing by a purchaser for contractual purposes;
- c) ongoing inspection by a regulatory or certification authority.

Annex B (normative)

Sampling plans intended for assessing compliance of isolated lots

Use of the sampling plans given in Annex A for small numbers of lots, i.e. fewer than five, results in a higher level of consumer risk because the switching rules are not available. In such circumstances, the use of larger sample sizes is recommended in order to maintain an acceptable level of consumer protection. The choice of a suitable sampling plan is governed by cost considerations. Larger sample sizes give better discrimination, but at increased cost. Purchasers may, for example, rely upon their experience with a particular supplier when assessing the sample sizes to use for small numbers of lots.

The sampling plans given in Table B.1 for normal inspection, where applied to isolated lots, provide approximately the same level of consumer protection as those given in Annex A when used in conjunction with the switching rules. Attention is drawn to the possibility of using double or multiple sampling plans, which can reduce the total number of dams that need to be tested to demonstrate compliance when quality is significantly better than the AQLs.

NOTE There is no simple mathematical relationship between the sample size and the lot size. Sample sizes can be increased independently of the lot size to achieve a more reliable estimate of lot quality.

Table B.1 — Sampling plans and acceptance criteria for isolated lots

Attribute	Inspection level ^a	Acceptance criterion
Dimensions	13 dams	All samples shall fall within the manufacturer's specified limits
Tensile and tear properties	Special inspection level S-3 but at least 32 samples	AQL of 2,5
Package integrity	Special inspection level S-3 but at least code letter H	AQL of 2,5
Freedom from holes	General inspection level I but at least code letter N	AQL of 0,25
Visible defects	General inspection level I but at least code letter N	AQL of 1,0
Packaging and labelling	13 consumer packages and 13 individual containers	All shall comply
^a See ISO 2859-1 where relevant.		

Applications for these sampling plans can include the following:

- a) type testing as part of a certification procedure;
- b) cases where the total number of lots being assessed is insufficient to allow the switching rules to be effective;
- c) cases of dispute involving isolated lots, e.g. for referee testing.

Annex C (normative)

Determination of length and width

C.1 Principle

The length and width of the dam are measured using a ruler.

C.2 Apparatus

C.2.1 Ruler, graduated in millimetres.

C.3 Procedure

Lay the barrier membrane (dam) flat on a flat surface. Measure the length and width of the barrier membrane (dam) using the ruler.

C.4 Expression of results

Report the length and width of each tested dam to the nearest millimetre.

Annex D **(normative)**

Determination of dam thickness

D.1 Principle

The thickness is measured with the use of a micrometer dial gauge.

D.2 Apparatus

D.2.1 Micrometer, dial or digital type, with resolution 0,001 mm, foot diameter between 3 mm and 10 mm, and foot pressure at (22 ± 4) kPa, parallel to a flat base plate.

D.3 Method

Using the micrometer dial gauge, take nine thickness measurements in total, near each corner, near the midpoint of each side and in the centre.

D.4 Test results

Report the mean and range of the results.

Annex E (informative)

Guidance for risk assessment

E.1 General

A risk assessment identifies and estimates the seriousness of potential hazards associated with the use of the prophylactic dam and helps determine whether these risks are acceptable.

E.2 Background

E.2.1 ISO 14971 provides a full reference to risk assessment as a component of risk management.

E.2.2 The risk assessment is intended to provide pre-production risk analysis and evaluation, not risk control or post-production information.

E.3 Risk assessment process

E.3.1 The manufacturer should describe the intended use/intended purpose of the dam.

- a) The intended use/intended purpose of the dam is based on the device specifications, instructions and all other information provided by the manufacturer.
- b) The intended use includes any reasonably foreseeable misuse of the product.

E.3.2 The manufacturer compiles a list of known or foreseeable hazards associated with the dam in both normal and fault conditions. Reasonably foreseeable sequences of events that can result in a hazard situation should be included.

E.3.3 The risks in both normal and fault conditions are then estimated based upon:

- a) the probability of the occurrence of harm;
- b) the consequences (e.g. severity) of that harm;
- c) the likelihood that the hazard can be identified before a risk situation occurs.

Risks should be estimated using all available information or data. Where the probability of harm cannot be estimated, a list of possible consequences of the hazard should be prepared.

E.3.4 There are a number of established techniques for the assessment of risk. These techniques are often complementary and a manufacturer may choose to use more than one of these techniques. These techniques are further described in ISO 14971. The techniques are

- a) failure mode and effect analysis,
- b) fault tree analysis, and
- c) hazard and operating study.

E.3.5 For each identified hazard, the manufacturer decides for each hazard whether the estimated risk(s) requires risk mitigation and controls.

E.4 Impact of risk assessment

Risk assessment is one component of a whole risk management system. If the result of the risk assessment is that the risk(s) is/are not acceptable, the manufacturer should re-evaluate the design of the dam and/or implement controls and mitigations as part of the risk management system.

If the result of the risk assessment is that the risk(s) is/are acceptable, the hazards and failures identified in E.3.2 (above) shall be evaluated in accordance with ISO 14971.

Annex F (normative)

Determination of barrier properties using the bacteriophage method

F.1 General

This annex provides the rationale, methodology and required sensitivity to test the ability of a dam to act as a barrier to transmission of the etiological micro-organisms of STIs, including viruses. For latex dams that pass the freedom from holes test, this determination is not required.

A dam is a medical device designed to prevent the transmission of micro-organisms that can cause STIs during sexual intercourse. In order to make a claim that a dam is effective against STIs, appropriate laboratory tests shall be performed. Since viruses are the smallest etiological STI agents, the challenge particle should be a small virus or virus-size particle. The challenge particle, solution properties, test pressure and test duration should be chosen to simulate, as closely as possible, real-use conditions. Choices of parameters that make the *in vitro* test more stringent than expected real-use conditions are encouraged, with appropriate justification. However, movement of the dam during the test is not required.

The choice of a challenge particle has several important aspects. Signal-to-noise ratio should be considered. A biological assay might be preferred in general because the expected background "noise" signal of a biological assay is less than that of an assay using radioactive or other labelled viruses or virus-like particles.

In order for the test to be used to demonstrate safety with regard to STI barrier properties, the test virus shall be smaller than the hepatitis B virus (42 nm diameter), the smallest etiological agent for an STI. Surrogate viruses, such as bacterial viruses (bacteriophages) of appropriate size and shape can act as substitutes for human pathogens. This protocol suggests the use of a small bacteriophage as the challenge particle because bacteriophage assays are safe, fast and comparatively less expensive than alternate assays. Additionally, bacteriophages can be readily obtained at sufficient titre to provide an adequate challenge concentration. The bacteriophage phi-X 174 should be considered as the challenge virus. Other similar challenge bacteriophages may be used, but shall be demonstrated to be equivalent to phi-X 174.

F.2 Sample size

Use a minimum of 20 dams, 10 from each of two lots, in order to determine acceptability.

F.3 Preparation of test samples

F.3.1 Handle test dams carefully so they are not damaged during the test procedure.

F.3.2 Wear gloves as a precautionary measure to prevent abrasion or puncture by fingernails, rings, etc.

F.3.3 Remove accompanying lubricants and/or spermicides, if present, to prevent interference with the test. Wash using isopropanol or water and detergent as appropriate and dry the dam to constant mass, ± 10 mg, without damaging the dam material.

F.4 Procedure

F.4.1 Principle

The test consists of placing the dam with virus-containing buffer above it and a collection buffer below it, and determining whether any viruses penetrate the dam barrier during exposure. Virus penetration is quantified and reported as the equivalent volume of penetrating challenge buffer needed to account for the amount of virus penetration into the collection buffer. Positive control experiments of the same duration are needed to ensure that the overall test is functioning properly.

F.4.2 Test apparatus requirements

F.4.2.1 The device shall provide a 75 mm diameter clear tank at least 15 cm high above the dam and a 75 mm clear tank below it. The dam shall be clamped between two flat plates attached to the tanks and sealed with O-rings. A watertight seal between the plates shall be demonstrated before each test begins.

F.4.2.2 The test apparatus shall provide a leakproof seal at the dam between the two buffers, and the structure of the mount shall divert any possible leakage around the seal from the collection buffer.

F.4.2.3 The apparatus shall restrain the dam to prevent over-expansion under pressure.

F.4.2.4 The apparatus shall provide access to the challenge virus suspension inside the dam for assay following the test.

F.4.3 Buffer requirements

F.4.3.1 The challenge buffer solution and the collection buffer solution shall have pH a value of approximately 7.

F.4.3.2 The challenge buffer solution and the collection buffer solution shall have the salinity of any one of several variations of physiological saline.

F.4.3.3 The challenge buffer solution and the collection buffer solution shall have a surface tension less than 0,05 N/m.

F.4.3.4 The challenge buffer solution shall contain the challenge virus at adequate titre at the beginning of the test so that even at the end of the test the titre is sufficient. Sufficient titre for a small, approximately spherical virus is at least 10^8 plaque forming units per millilitre (pfu/ml).

NOTE One adequate buffer that has been successfully demonstrated is 0,1 % Triton X-100^{®1)}. Physiological saline has a lower viscosity than semen and therefore provides a more stringent test. The test can be performed at room temperature (25 ± 2) °C when saline is used.

F.4.4 Sample testing

F.4.4.1 Mount the dam on the support structure.

F.4.4.2 Introduce the collection buffer to the space under the dam.

F.4.4.3 Introduce the challenge buffer to the space above the dam.

F.4.4.4 Apply pressure to the internal volume of the dam, such that the pressure of the challenge fluid is equivalent to 1 kPa or more, i.e. use a challenge column 10 cm high.

1) Triton X-100[®] is an example of a suitable product available commercially. This information is given for the convenience of users of this International Standard and does not constitute an endorsement by ISO of this product.

- F.4.4.5** Leave the dam position between the challenge buffer and the collection buffer for at least 30 min.
- F.4.4.6** Mix the collection fluid just prior to assaying so that the assay aliquots are representative.
- F.4.4.7** Assay the collection buffer for the challenge virus to determine whether any virus has penetrated the dam and passed into the collection buffer.
- F.4.4.8** Calculate the equivalent volume of challenge virus penetration needed to account for the amount of virus found in the collection buffer.

F.4.5 Positive control testing

Use positive controls that meet the following requirements.

- a) Follow the same procedure as in F.3 and F.4.4, using dams with representative (approximately 30 µm diameter) pinholes placed using a small gauge needle, laser or other suitable method.
- b) Verify stability of virus concentration. Determine whether the challenge virus remained at a stable concentration in the dam during the test. Data from several positive control dams shall be collected as part of each dam test. The titre of the challenge virus suspension inside the dam at the end of the test is compared to the titre originally placed in the dam. This determines if and how much the challenge virus titre changes during the test because of interaction with the dam and the test apparatus, or other factors.
- c) Verify detectability. Determine whether any virus that penetrates the dam remains detectable in the collection buffer over the test period. This can be done by "spiking" the collection buffer with a low level of virus before a mock test (where there is no virus inside the dam and for the same duration) and assaying the titre of the collection buffer at the beginning and end of the mock test. This determines if and how much the penetrated virus titre changes during the test as a result of interaction with the outside of the dam, the restrainer or the collection container.
- d) Increase the starting titre of the challenge virus if the stability controls or the detection controls (or both) indicate the loss of virus titre below 10^8 plaque forming units per millilitre to compensate for the loss and to maintain the overall sensitivity of the test.
- e) It can be useful to determine via controls (e.g. settle plates) whether contamination caused by aerosolized virus or other leaks might lead to false evidence of virus penetration of the dam.

F.4.6 Negative control testing

Repeat the test on at least three dams, previously tested for freedom from holes, which have been cut open.

F.5 Detection limits and reporting

F.5.1 Detection limit explanation

F.5.1.1 For a 95 % confidence that an assay finds at least one virus when virus is present [i.e. $P(0) < 0,05$], the average number of infectious particles per total volume assayed shall be at least three; e.g. there is a 95 % probability that a titre of 1 pfu/ml results in at least one plaque in a 3 ml total assay. Thus, the sensitivity or detection limit of this assay can be claimed as 1 pfu/ml whenever 3 ml are assayed.

F.5.1.2 Detection limit expressed as volume of challenge virus suspension that penetrated the barrier is probably the most useful measure of test sensitivity. For example, in a real-life risk assessment the volume of transmitted virus-containing fluid can be translated into infectious units whenever the titre of a pathogenic virus (in real life) is known.

F.5.1.3 The test procedure shall be able to detect a 2×10^{-6} ml penetration of the challenge virus suspension. This can be done by:

- a) using a challenge buffer titre of 1×10^8 pfu/ml;
- b) using a collection buffer volume of 200 ml;
- c) assaying 1 ml in triplicate from the collection buffer (assuming no loss of virus titre in the challenge buffer nor in the collection buffer): the assay detection limit of 1 pfu/ml is equivalent to penetration by 200 pfu ($1 \text{ pfu/ml} \times 200 \text{ ml}$) or 2×10^{-6} ml (200 pfu divided by 1×10^8 pfu/ml).

F.5.2 Detection limit analysis

F.5.2.1 Assay at least 1 ml in triplicate (3 ml total).

F.5.2.2 Present the individual results for each dam sample tested in a table that includes

- a) the challenge buffer virus titre,
- b) the virus titre in the collection buffer,
- c) any correction factor for loss of virus (determined in the controls), and
- d) the calculated challenge volume that penetrated (for the dams that allowed virus transmission). This value of the volume of challenge virus suspension needed to account for the virus penetration into the collection buffer can be calculated for each dam by the method presented in F.5.1. If some loss of virus titre occurs, either inside the dam or outside in the collection container, the calculation should include the appropriate correction for such loss. For dams that apparently did not allow virus transmission, the detection limit of that particular test should be given, e.g. as 2×10^{-6} ml.

F.5.3 Reporting

F.5.3.1 Positive and negative control

Reporting the results of the positive and negative control experiments should be done using the same reporting format as with virus penetration of test samples.

F.5.3.2 Challenge virus stability

Results from the challenge virus stability test should be presented in tabular form, where the data for each dam are individually reported. Necessary items for each test sample include:

- a) the date the test was performed;
- b) the titre of challenge buffer placed inside the dam at the beginning of the test;
- c) the titre of challenge buffer inside the dam at the end of the test;
- d) the calculated ratio of final to beginning titre.

F.5.3.3 Challenge to virus detection

Results from tests carried out to determine the detection of penetrated virus should be presented in tabular form, where the data for each dam are individually reported. Necessary items for each test sample include:

- a) the date the test was performed;
- b) the titre of collection buffer at the beginning of the test;
- c) the titre of collection buffer at the end of the test;
- d) the calculated ratio of final to beginning titre.

Annex G (normative)

Determination of tensile properties

G.1 Principle

A sample cut from the dam is tested in a tensile tester, and the force and elongation at break are recorded. The tensile strength is calculated.

G.2 Apparatus

G.2.1 Tensile tester

Tensile testing machine capable of stretching samples to break, and of testing forces in the range 1 N to 30 N with an accuracy of better than 2 %.

G.2.2 Dumb-bell cutter

Cutting die capable of cutting type 1, type 1A or type 2 samples as specified in ISO 37.

G.3 Procedure

G.3.1 Condition the latex barrier membranes (dams) at (25 ± 5) °C and a relative humidity of (55 ± 15) % for at least 16 h prior to tensile testing.

G.3.2 Cut three dumb-bell samples of type 1 or type 2 as specified in ISO 37 from each dam.

G.3.3 Carry out the test in accordance with ISO 37 under a controlled temperature of (25 ± 5) °C and a relative humidity of (55 ± 15) %.

G.4 Expression of results

Record the force and elongation for each sample and calculate the individual tensile strengths. Report the median tensile strength for the three samples from each dam tested.

Annex H **(normative)**

Oven conditioning

H.1 General

For provisional shelf-life determination, prophylactic dams may be conditioned in an oven in their original individual packages.

H.2 Apparatus

H.2.1 Oven, of either type specified in ISO 188. Suspension of the individual packages, as indicated in ISO 188, is not required.

H.3 Preparation of prophylactic dams for test

Remove the individual container from any consumer and/or outer packages before conditioning.

H.4 Procedure

H.4.1 Mount the prophylactic dams in sealed individual containers in the oven in such a manner as to minimize direct contact of the specimens with the heated surfaces, especially the base of the oven. This ensures even heating of the prophylactic dams during oven conditioning.

H.4.2 Condition the dams at the temperature and humidity stipulated in the relevant clause or annex of this International Standard.

H.4.3 Remove the dams from the oven after the time stipulated in the relevant clause or annex of this International Standard.

H.4.4 Store the packages at (25 ± 5) °C until tested.

H.4.5 Test all samples within 96 h, but not sooner than 12 h, after removal from the oven, in accordance with the relevant clause or annex of this International Standard.

Annex I (normative)

Determination of shelf-life by real-time stability studies

I.1 Principle

To simulate storage conditions worldwide, packaged dam samples are conditioned at (30_{-2}^{+5}) °C for the intended shelf-life period. Following conditioning, the samples are subjected to testing for conformance with the requirements for tensile strength and freedom from holes given in Clauses 9 and 11. To monitor changes during the ageing period, samples shall also be subjected to the same testing at regular intervals before the end of the intended shelf-life.

I.2 Procedure

I.2.1 General

After determining conformity to Clauses 9 and 11, sufficient dams shall be placed in a controlled environment and conditioned at (30_{-2}^{+5}) °C. Shelf-life shall be confirmed if dams meet the requirements of Clauses 9 and 11 after conditioning for a period equal to the intended shelf-life claim.

I.2.2 Conditioning

I.2.2.1 Condition samples from three lots of dams packed in their respective individual containers in accordance with Annex H at (30_{-2}^{+5}) °C.

I.2.2.2 Condition enough dams per lot to ensure sufficient samples (at least 13) can be tested for conformity to Clause 9 at intervals of one year or less over the duration of the proposed shelf-life period.

I.2.2.3 Condition enough dams per lot to ensure sufficient samples can be tested for conformity to Clauses 9 and 11 at the end of the proposed shelf-life period, in accordance with sample sizes required in Annex B.

Although the suggested minimum is 400 dams, it is strongly recommended that additional dams be conditioned as spares in case there is a need for any re-testing or in case additional time points are required.

I.2.3 Testing

I.2.3.1 Remove sample dams from the controlled environment at intervals determined according to I.2.2.2.

I.2.3.2 Determine tensile and tear properties in accordance with Annex G. Plot the mean and standard deviation of the bursting force at break, elongation at break and tear force against time for each lot. At the end of the proposed shelf-life period, or if the mean and standard deviation of the tensile properties as monitored deteriorate to the point where the dams can be approaching the limit of complying with the requirements of Clause 9, test sufficient dams per lot using the sampling plan in Annex B.

I.2.3.3 Determine freedom from holes in accordance with Annex K and assess conformity to the requirements of Clause 11.

I.3 Confirmation of shelf-life claim

Upon completion of the procedure specified in I.2, the shelf-life claim shall be up to that period, not to exceed five years, for which the dams have complied with the requirements of Clauses 9 and 11.

If the labelled shelf-life is more than the confirmed shelf-life, the manufacturer shall adjust the shelf-life claim and notify the regulatory authorities and direct purchasers.

I.4 Test report

Report the following:

- a) the individual tensile property results for each of the dams at all the times tested;
- b) the plot of average tensile force and elongation against time, the number of non-conforming units and the distribution curves;
- c) the freedom from holes and visible defects results for each lot, as identified in K.3;
- d) the confirmed shelf-life claim.

Interim test reports shall be made available to appropriate regulatory bodies on request, to document that the real-time study has begun.

Annex J (informative)

Guidance on conducting and analysing accelerated ageing studies

J.1 General

Accelerated ageing studies should be used to support provisional shelf-life claims pending completion of real-time studies. This annex describes general procedures that may be used for conducting accelerated ageing studies to estimate shelf-life for market introduction while real-time studies are in progress.

Where a manufacturer has determined the shelf-life of an existing product through real-time stability studies and has established a set of accelerated ageing conditions that can be used to verify the shelf-life of this product, the procedure described in J.3 can be used to establish a provisional shelf-life for a new or modified product. Otherwise, an accelerated stability study should be conducted using the conditions specified in J.2.

J.2 Procedure for determining a provisional shelf-life in the absence of a control dam with real-time stability data

In the absence of real-time stability data for an appropriate control product, manufacturers should conduct a stability study at (50 ± 2) °C on three production lots of dams, as described in J.4.

Depending on the period of the study, the following provisional shelf-life may be assigned to the product:

- a shelf-life of two years after a period of 90 days;
- a shelf-life of three years after a period of 120 days;
- a shelf-life of five years after a period of 180 days.

J.3 Procedure for determining a set of ageing conditions using a control dam with real-time stability data

This procedure can only be used when a control dam is available for which the shelf-life has been determined by a real-time study. Condition dams from a minimum of two production lots of control dams and three production lots of the new or modified dams in ovens at selected temperatures in accordance with Annex H. It is recommended that a minimum of two temperatures be used. At appropriate time intervals, remove samples of dams from the oven and determine the tensile properties according to Annex G. A minimum of five time points at the selected temperature(s) is recommended. It is recommended that at least 13 dams be tested at each time/temperature point.

Compare the changes in tensile properties of the control and test dams at different time points and temperatures. Based on this comparison, establish an equivalent set of ageing conditions for the new dam that can be used to assess the provisional shelf-life of the product.

J.4 Evaluation of provisional shelf-life

Take samples of dams from three lots. It is recommended that sampling be in accordance with Annex B. Condition the samples according to Annex H using the ageing conditions specified in J.2 or determined according to J.3 depending upon the procedure being used. Manufacturers should ensure that precautions are taken to monitor temperatures during the conditioning period and have adequate contingency arrangements in place to respond to any loss of temperature control caused by equipment breakdown or loss of power.

Remove the dams from the oven and assess compliance with the requirements of Clauses 9 and 11. If all lots are in compliance, the appropriate provisional shelf-life can be assigned to the product.

For convenience, the ageing temperatures may be selected as 70 °C and 50 °C and, provided the ageing periods at these temperatures equal or exceed 7 days at 70 °C and 90 days at 50 °C, this test can also be used to verify the requirements of 10.2.

In order to save time, it can be appropriate to conduct the studies described in J.3 and J.4 in parallel.

Annex K (normative)

Testing for holes

K.1 General

This annex specifies the water leak method for testing dams for visible and non-visible holes, tears and visible defects.

K.2 Water leak test

K.2.1 Principle

Dams are visually inspected then exposed to water and examined for visible water leakage through the wall.

K.2.2 Apparatus

K.2.2.1 Reservoir of water greater than 50 mm in diameter, extending at least 150 mm above the orifice, connected by a U-tube to a 100 mm orifice plate. A matching plate, which can be clamped to the orifice plate, is used to seal the dam into position for testing.

Suitable clamping method to hold the dam in position without leakage.

K.2.2.2 Gloves.

K.2.2.3 Water source.

K.2.2.4 Test rack.

K.2.2.5 Stopwatch.

K.2.3 Procedure

K.2.3.1 Wear suitable gloves when handling the prophylactic dams so as to avoid damage to the prophylactic dam by fingernails, jewellery, etc.

K.2.3.2 Remove the dam from its pack, examine it for visible defects, and place it on the test orifice. Clips may be used to keep it reasonably tight, without undue stretching (<10 %).

K.2.3.3 Apply the top plate.

K.2.3.4 Fill with water at 10 °C to 40 °C to give a pressure head of 100 mm on the dam.

K.2.3.5 Examine the dams for signs of leakage.

K.2.4 Interpretation of test results

Dams with visible or non-visible holes or tears and dams with visible defects are considered non-conforming.

K.3 Test report

Upon completion of the test, record the following data:

- a) the number of dams tested;
- b) the number of dams with visible or non-visible holes located;
- c) the number dams with visible defects observed.

Dimension in millimetres

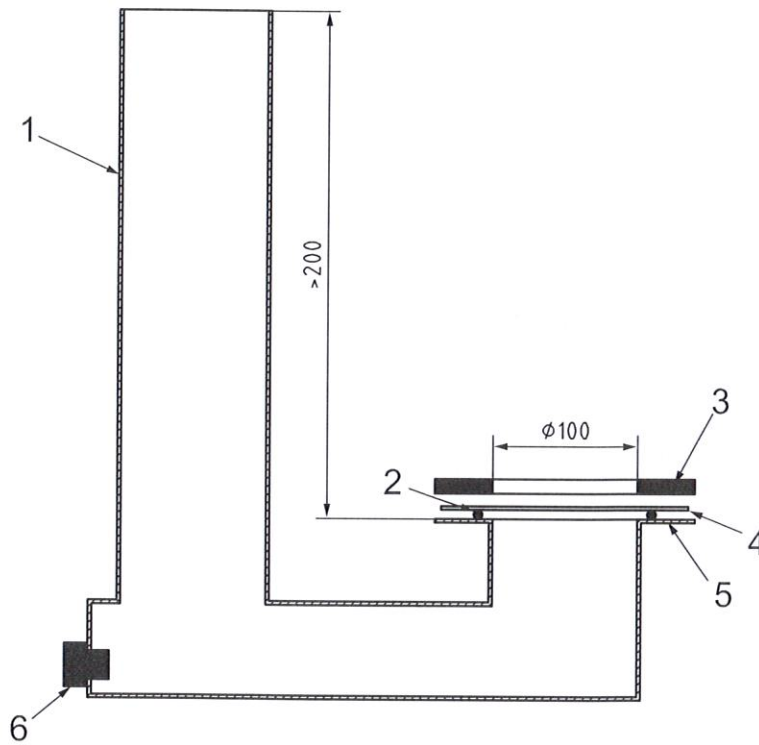

Key

- 1 pipe
- 2 O-ring
- 3 top plate
- 4 dam
- 5 bottom plate
- 6 drain plug

Figure K.1 — Test apparatus

Bibliography

- [1] ISO 14155, *Clinical investigation of medical devices for human subjects*
- [2] ISO 16038, *Rubber condoms — Guidance on the use of ISO 4074 and ISO 23409 in the quality management of natural rubber latex condoms and synthetic condoms²⁾*
- [3] ASTM D3078, *Standard test method for determination of leaks in flexible packaging by bubble emission*

2) Under preparation.

BS ISO 29942:2011
ISO 29942:2011(E)

ICS 11.200

Price based on 29 pages

© ISO 2011 – All rights reserved

British Standards Institution (BSI)

BSI is the independent national body responsible for preparing British Standards and other standards-related publications, information and services.

It presents the UK view on standards in Europe and at the international level.

It is incorporated by Royal Charter.

Revisions

British Standards are updated by amendment or revision. Users of British Standards should make sure that they possess the latest amendments or editions.

It is the constant aim of BSI to improve the quality of our products and services. We would be grateful if anyone finding an inaccuracy or ambiguity while using this British Standard would inform the Secretary of the technical committee responsible, the identity of which can be found on the inside front cover.

Tel: +44 (0)20 8996 9001 Fax: +44 (0)20 8996 7001

BSI offers Members an individual updating service called PLUS which ensures that subscribers automatically receive the latest editions of standards.

Tel: +44 (0)20 8996 7669 Fax: +44 (0)20 8996 7001

Email: plus@bsigroup.com

Buying standards

You may buy PDF and hard copy versions of standards directly using a credit card from the BSI Shop on the website www.bsigroup.com/shop. In addition all orders for BSI, international and foreign standards publications can be addressed to BSI Customer Services.

Tel: +44 (0)20 8996 9001 Fax: +44 (0)20 8996 7001

Email: orders@bsigroup.com

In response to orders for international standards, it is BSI policy to supply the BSI implementation of those that have been published as British Standards, unless otherwise requested.

Information on standards

BSI provides a wide range of information on national, European and international standards through its Knowledge Centre.

Tel: +44 (0)20 8996 7004 Fax: +44 (0)20 8996 7005

Email: knowledgecentre@bsigroup.com

Various BSI electronic information services are also available which give details on all its products and services.

Tel: +44 (0)20 8996 7111 Fax: +44 (0)20 8996 7048

Email: info@bsigroup.com

BSI Subscribing Members are kept up to date with standards developments and receive substantial discounts on the purchase price of standards. For details of these and other benefits contact Membership Administration.

Tel: +44 (0)20 8996 7002 Fax: +44 (0)20 8996 7001

Email: membership@bsigroup.com

Information regarding online access to British Standards via British Standards Online can be found at www.bsigroup.com/BSOL

Further information about BSI is available on the BSI website at www.bsigroup.com/standards

Copyright

Copyright subsists in all BSI publications. BSI also holds the copyright, in the UK, of the publications of the international standardization bodies. Except as permitted under the Copyright, Designs and Patents Act 1988 no extract may be reproduced, stored in a retrieval system or transmitted in any form or by any means – electronic, photocopying, recording or otherwise – without prior written permission from BSI. This does not preclude the free use, in the course of implementing the standard of necessary details such as symbols, and size, type or grade designations. If these details are to be used for any other purpose than implementation then the prior written permission of BSI must be obtained. Details and advice can be obtained from the Copyright & Licensing Manager.

Tel: +44 (0)20 8996 7070

Email: copyright@bsigroup.com

BSI Group Headquarters

389 Chiswick High Road London W4 4AL UK

Tel +44 (0)20 8996 9001

Fax +44 (0)20 8996 7001

www.bsigroup.com/standards